



**RT Models**

## 4mm scale, 00/EM/P4 Manning Wardle, class K 0-6-0ST loco kit

### History

The first of Manning Wardle's Class K was built in 1864.

Many of these locos were mainly built for contractors with only a weather board on top of the firebox to protect the crew from the weather.

There is a lot of variations in these locos from cabs, buffers, brakes, sandboxes etc. It would be impossible to list them all as there is that many and these usually happened to the same loco!

A lot of these locos passed to industrial railways with the odd few ending up with both mainline and light railways.

Just to confuse matters, some "Old Class I"s are referred to as K class altered when some alterations to boiler length and cylinder dimensions occurred!

The rear wheelbase should be of equal length to the front and not shorter at the rear as on the Old class i.

The most well know loco's is "Ringing Rock" that ended its days on the Selsey Tramway and "Aldwyth" which is now preserved at the Amley mills museum in Leeds.

### Useful references

The locomotive built by manning wardle and company, volume 2 standard gauge by Fred W Harman, century loco Prints publication. ISBN 0953531317

The Selsey tram by David Bathurst, Phillimore. ISBN 0850338395

Branch line to Selsey, Middleton Press, ISBN 0906520045

Model Railway Journal. No. 12 of 1987 contains a very useful article on the Colonel Stephens pair of Old Class I's and drawings plus about Ringing Rock.

### Contents

#### Chassis etches

- E1. Chassis sides
- E2. front frame spacer
- E3. Centre frame spacer
- E4. Rear frame spacer
- E5. Cylinder front covers
- E6. Guard irons
- E7. Front chassis braces
- E8. Spring balance arm
- E9. Spring balance bracket
- E10. Handbrake brackets for steel brakes
- E11. Compensation rocker arms
- E12. Inside valve gear slide bars
- E13. Inside valve gear inner rods
- E14. Inside valve gear outer rods
- E15. Wooden brakes
- E17. brakes pull rods
- E18. Steel brakes
- E19. brake pull rods
- E20. Hand brake arms
- E21. Steel hand brake linkage
- E22. Fixed coupling rods
- E23. Jointed coupling rods

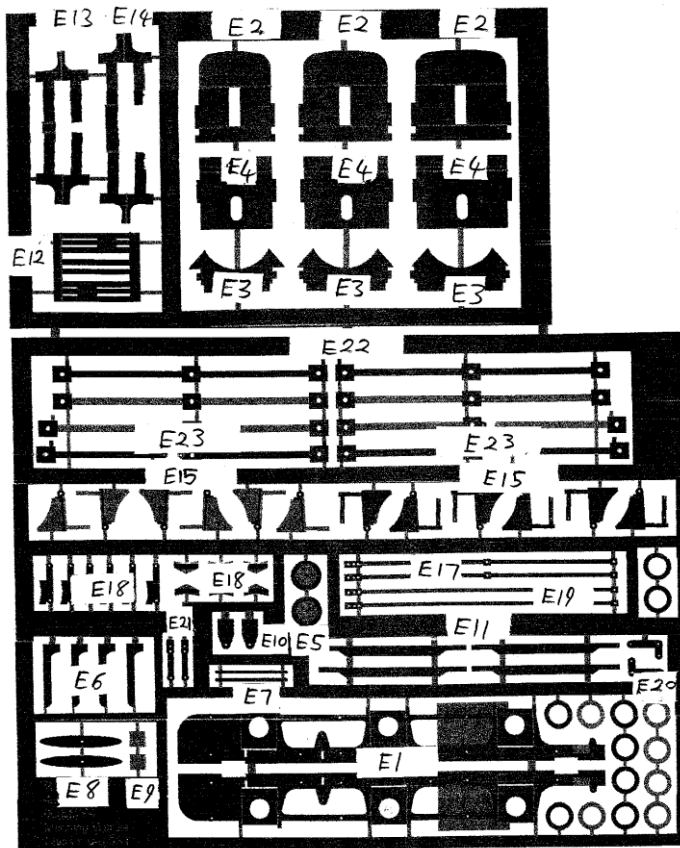

### Body etches

- E30. Footplate
- E31. Footplate strips
- E32. Buffer beams
- E33. Buffer beam overlays
- E34. Front buffer beam supports
- E35. Wheel arches-plain
- E36. Wheel arches-stripped
- E39. Wheel arch rear covers
- E40. main plain bunkers sides
- E41. 3X overlay plain bunkers sides
- E42. main flared bunkers sides
- E43. 3X overlay flared bunkers sides
- E44. Extra flared bunker tops
- E45. Inside partition bunkers flared
- E46. Bunker hatches flared
- E47. Bunker internal bracket flared
- E48. Bunker plain front
- E49. Reversing lever
- E50. Reversing rod
- E51. cab sides
- E52. Cab Steps
- E53. smokebox front
- E54. Smoke box wrapper
- E55. Smoke box door
- E56. Saddle tank main
- E57. Saddle tank main ends
- E58. Saddle tank sides overlay
- E59. Saddle tank ends overlay
- E61. Wheel arch surrounds
- E64. Cab Weatherboard
- E65. MW cab
- E69. MW cab long strips
- E70. MW cab short strips
- E72. Spring balance arms
- E73. smoke box hand wheels
- E75. saddle tank mounting brackets

- E76. Lamp irons
- E77. Morous bunker lamp irons
- E78. Etched firebox and front
- E79. Smokebox side extensions

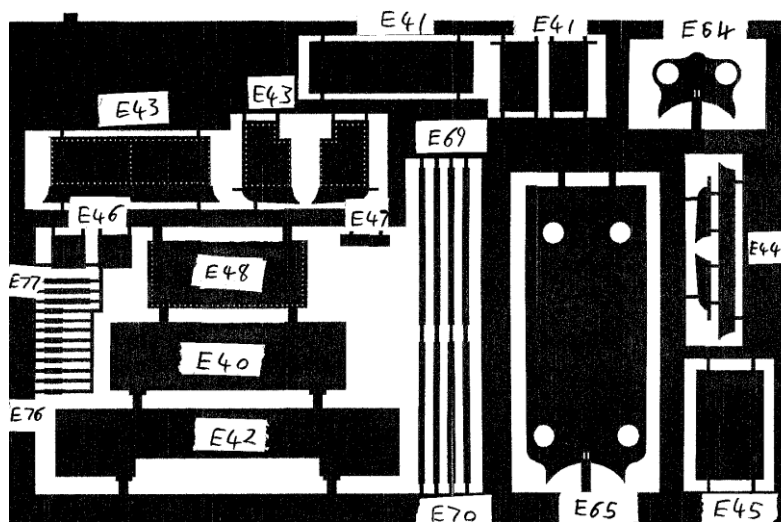
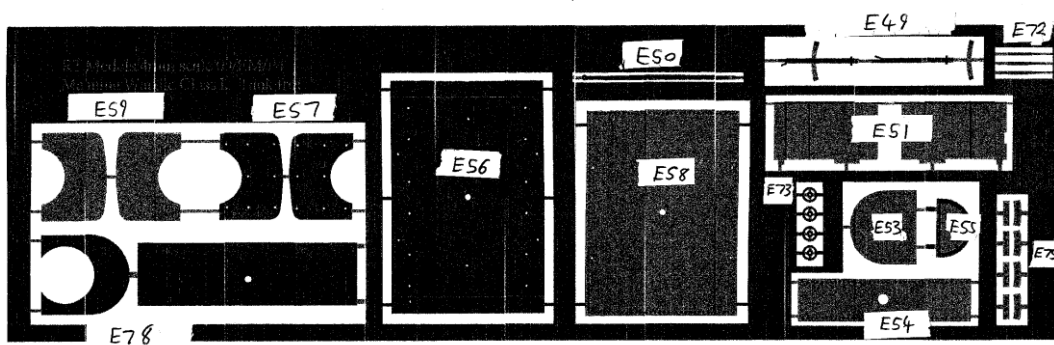
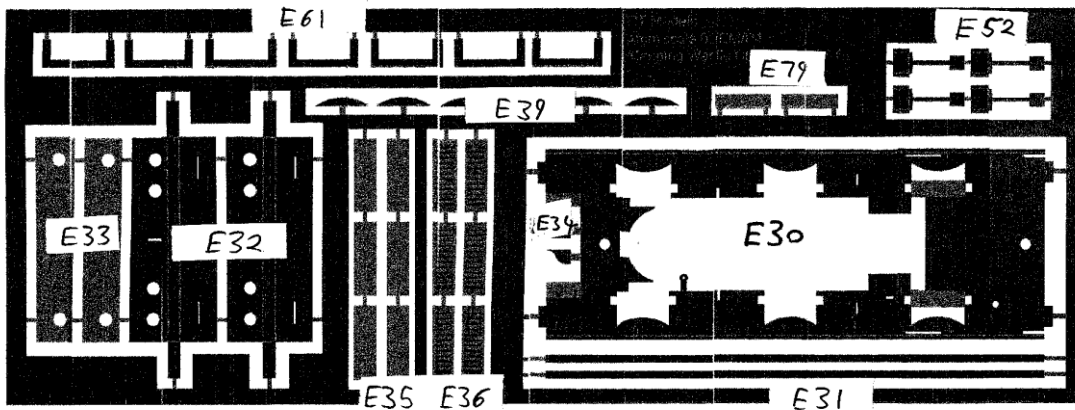

### white metal castings

- C1. smoke box
- C2. Boiler
- C4. Firebox backhead
- C5. Round smoke box door
- C6. Saddle tank filler
- C7. 2x small sandboxes
- C8. 2x large sandboxes
- C9. 4x parallel buffers
- C10. 4x tapered buffers
- C11. 4x Extended dumb buffers
- C12. 6x cast springs

C13. Vacuum brake  
C14. chimney

### Lost wax brass castings

LBW1. E.B.Wilson safety valve dome cover  
LBW2. E.B.Wilson safety valve dome base  
LBW3. tapered safety valve dome cover  
LBW4. 2x Clacks  
LBW5. Safety valve springs  
LBW6. 2x Clack pipe joins  
LBW7. Handbrake  
LBW8. Regulator handle  
LBW9. Whistle

### brass fittings

B1. 2x 10BA nuts and bolts  
B2. 5x handrail knobs  
B3. length of 0.45mm brass wire

## Additional parts required

- Driving wheels, Alan Gibson G4836IW Manning Wardle 8 spoke 3' wheels, 12MM and appropriate crankpins
- PCB sheet or strip and Phosphor Bronze wire for pickups
- Motor and Gearbox of your preference, I personally recommend High Level Kits range of gearboxes. It may be possible to fit a HLK roadrunner compact + driven off the middle axle with a Mashima 1015 flat can mounted vertically inside the firebox but may require some material to be removed from inside of the firebox.
- If building your chassis with compensation or springing, your preferred brand of hornblocks.

## Chassis

### Mainframes

First remove the E1 chassis sides from the fret with a Stanley knife, carefully file the remaining tabs off.

You will need to decide at this point which version of loco and types of brakes you want to build.

If you wish to build Ringing Rock, leave the chassis frames as they are. See Fig 1

If you wish to fit small metal type brake blocks, you will need to cut and file the front part of the E1 chassis frames up to the first half etched outline, See Fig 2

If you wish to fit Large wooden Brake blocks, you will need to trim and file up to the second half etched outline, See Fig 3

Now open up the large bearing holes slowly with a tapered reamer checking with the bearings to make sure they are a tight fit and not sloppy which can cause problems during construction and also poor running.

If you are planning on building the chassis with beam compensation or springing, at this stage carefully cut the hornguide outlines with a piercing saw then clean up with a small flat needle file. With some flux, carefully tin the insides of the chassis with solder around the slots ready for the frame spacers.

Cut the 3 frame spacers E2, E3 & E4 for your required gauge from the frame spacer fret.

Fold E2 and E4 frame spacers with the half-etched line inside the fold to 90 degrees, Tin the insides of the frames with solder as this will help soldering.

If you are to fit a compensation beam to the front 2 axles, you may need to file a slot into the centre frame spacer to allow this. This is much easier to do **before** the spacer is assembled to the frames!

There is provided a pair of E11 etched axle rocker arms that are designed to slot between the E1 chassis sides and the centre E3 frame spacer but to be honest whilst this is possible, it will be difficult with little room to work easily.

If you do want to use the etched axle rockers, the bottom of the centre E2 frame spacer will need to be filed slightly back to ensure they slot into and work freely. The E3 frame spacer can be inserted after soldering the chassis sides and outer frame spacers by gently prising out the chassis sides.

Insert the frame spacers into the slots making sure at the outer ends the slotted holes are at the top. Make sure the whole chassis is square, once you are happy then solder the insides.

Once you are happy with it, you can turn to fitting the bearings. Insert them into the holes, and then with a spare axle or alignment jigs, insert them into the bearings to line them up square, solder the bearings into place from the inside avoiding getting flux onto the axle if possible.

Next solder the E5. Cylinder covers to the front of E2 frame spacer.

Solder E7. Front chassis support to the front of the chassis if you are modelling the early loco as in Fig 3..

Depending on your loco if it had them fitted, fold up the E6. Guard irons and solder into place.

### *Coupling Rods and Wheels*

Now assemble the coupling rods, you will need to decide how you want them made up, solid, jointed from the crankpin or the rod itself.

When assembling the coupling rods, tin the surfaces first and then soldering the 2 sides together with the aid of cocktail sticks to help align them.

- If the chassis is to be built rigid and the coupling rods are to be solid, just laminate the full thickness and half thickness rods together from E22.

### *Jointed Rods*

- There are two options provided for in the kit if you wish to have jointed rods (essential with compensation or springing). Please refer to diagrams 4a and 4 b. The joint can either be made on the centre crankpin or, prototypically, by a pinned joint in front of the centre crankpin.
- If they are to be jointed on the coupling rods using parts E23, solder the sides together making sure you don't get solder into the forked ends. Now clean-up the flux residue and then remove any excess solder to make sure that when you assemble them that they work freely.
- At this stage, it would be best to drill out the coupling rods holes with the required drill size, if using Romford Crankpins, open the holes out with 1mm drill or a tapered cutting broach (available from Eileen's Emporium and other suppliers). If using Gibson wheels and crankpins, open the holes to 1.5mm.

Now fold a piece of cigarette roll up paper and insert this onto the end of the pivot point, then push the other coupling rod on and insert a piece of brass wire through the hole, before soldering it, put a drop of oil onto the paper as this will help not soldering up the joint solid.

Now solder the sides around the wire. Make sure the rod moves freely on the pivot. When it does then cut the remaining brass with and clean up with a small needle file. If it doesn't then it may free itself with a bit of force but not too much, if it doesn't then you will need to de-solder it and start again.

### *Wheels*

Be careful with Gibson wheels since they have steel tyres it is best not to handle them more than is necessary or fit them until all soldering operations are completed. They are also designed to be a press-fit on the axle and should not be removed from the axle more often than is necessary.

You must, however, establish that the chassis is square and runs properly. First, fit the wheels to the chassis and check that it runs without the rods. Once correctly quartered, add the coupling rods and test whether the chassis runs smoothly by pushing it along a bit of track. If it doesn't do so now, it won't when

motor and gears are added. If it does work freely then you can move onto finishing the chassis. If it doesn't then you will need to investigate why, which it can be a number of scenarios.

1. Coupling rod holes do not line up with the ends of the axles.
2. Incorrectly quartered wheels
3. Crankpin bent.
4. Axle bearings not lined up properly.

Take your time and once you are happy with its running, its best to take the wheels off when washing the chassis of flux in warm water with a tooth brush.

### ***Dummy Inside Valve Gear***

If you wish there is included on the chassis frame spacer etch a representation of the inside valve gear.

Remove the E12 dummy slide bars from the fret and fold the ends up.

Tin the ends of the slide bars and also the frame spacers where they attach to, especially both sides of the centre frame spacer.

Now push this between the 2 frame spacers with the folded ends facing downwards and roughly angled as on the drawing, use a pair of sprung loaded tweezers to hold this in place at one end whilst soldering.

Now cut the E13 inner coupling rods and E14 outer coupling rods on the frame spacer fret and clean these up.

Before folding, tin these to make life easier soldering them.

For both, the half etched lines running through them need folding 180 degrees with the half etched line on the outside. Now fold the smaller half etched lines with them on the outside. Reinforce the fold with solder.

Now take both and with the aid of sprung loaded tweezers, place both inside each other and clamp these to the centre frame spacer. Check that the ends don't foul the centre axle (or, if you have fitted compensation or springing, any of the parts associated with that), and when you are happy with the fit, solder these in place and clean up the chassis of flux.

At this stage, you need to decide depending on your personal preference

- If you want to paint the chassis (at least the outside for the moment) and install the wheels and gearbox ready and install the brake gear
- Install the brake gear and then fit the wheels and gearbox after painting the whole chassis

At this stage it would be best to install the pickups before fitting the brake gear as access will be limited once the brakes are installed.

### **Brakes**

Depending on your prototype, you will need to choose which types of brakes are needed.

For large wooden brakes, most locos that had these fitted to the rear of the outer wheels only but some did to the centre wheel as well so check your prototype.

For Small metal brakes, these were usually fitted to the fronts of all wheels.

On E15 wooden brakes, if possible the top of the arms partly etched holes drilled out with a 0.35mm drill so the E17 or E19. Wooden brake pull rods can be secured with a small piece of brass wire at each end, note this will need to outside the wheels so allow enough room for the wheels side play to avoid short circuits.

Only one E20. Handbrake arm is needed but will require the small part of the L shaped arm cut off as this is not required.

## **Body**

### **Footplate**

Remove the E30 footplate from the footplate etch and clean this up.

Next remove 2 E31 footplate strips and solder these to the underside of the footplate in the half etched line.

Place the footplate onto the completed chassis and check the clearances, if modelling 00 gauge you will

certainly need to file out the half etched wheel arch areas on the rear of the footplate for the wheels to fit within.

If you are modelling in EM or P4 gauge, the very front of the insides of the E30 footplate will need to be filed to match the width of the insides of the chassis.

Next remove the E32 bufferbeams and fold these up with the half etched lines on the inside.

Solder the buffer beams to the ends of the footplate with the open areas facing underneath where the strips have been fixed to.

Depending on your prototype, if it doesn't have central dumb buffers, solder E33 buffer beam overlays to the fronts of the E32 buffer beams.

Now fold up the remaining parts upwards on the E30 footplate which consists of the front boiler support brackets, reversing lever arm and firebox locating brackets and run a fillet of solder in all of these to strengthen them.

Now carefully solder the 10BA nuts over the central holes at either end of the E30 footplate making sure none gets inside.

Now solder close to the insides of the front of the footplate the E34 front buffer beam supports.

Next is the wheel arches.

If you so wish however you shouldn't need these as the C12 cast springs should cover this area.

There is 2 types of wheel arches provided, again depends on your prototype.

E35 plain wheel arch covers should be used and flush with the wheel arches and the left over ends tucked underneath the footplate and the E61 wheel arch surrounds added to the tops of the E61 footplate butted up to the faces of the wheel arches if your prototype had these wheel arch surrounds.

E36 ribbed wheel arches need the ends soldered to the top of the footplate. The edges of the wheel arch covers should be slightly over the wheels arches forming a slight lip.

For the rear wheel arches, solder on the backs E39 wheel arch rear covers so the wheels are not exposed and forms a solid unit.

If modelling 00 gauge you won't need to use E39 as they will foul the wheels.

There are extras provided if you wish to fit these to the centre and front wheel arches if modelling EM or P4 gauge, you won't be able to fit these if modelling 00 gauge..

At this point, take parts C1 Smoke box, C2 boiler and E78 firebox wrapper and front and check that they fit well without fouling anything. You may find depending on your chosen track gauge that the rear of the E78 firebox may foul the rear wheel arch. At this stage it would be best to file the offending areas.

The rear of the E78 firebox should be flush with the end of the open rear area of the C30 footplate.

Once you are happy with this, file the front edges of the firebox so its curved all the way round and not a right angle edge.

Once you are happy with these put them aside for later.

Now solder the 2 main E49 reversing levers together making sure the half etched areas are on the outside.

Now solder the small etch to the outside to match those on the main parts, this needs to be fixed on the side where the small lever at the top of the reversing lever faces right.

Solder the completed E49 reversing lever unit to the small slot on the o/s of the footplate in the cab.

Next slightly bend outwards from the centre on the E30 footplate the reversing lever arm.

Now slide the plain end of the E50 reversing rod into the small slot on the E49 reversing lever, then with the help of a small piece of fine brass wire, use this to locate the other end into the reversing lever arm on the E30 footplate and solder both ends in place.

Trim the excess wire.

Take both parts E51 cab sides and carefully form a bend and that the tabs match those on the footplate.

Place these temporarily on the E30 footplate and use C3 firebox to check clearances.

If the E51 cab sides do foul the E78 firebox or reversing rod, then the ends will need filing down to for the firebox to fit properly.

Once you are happy with the fit, solder the E51 cab sides in place.

### Coal bunker

Depending on your chosen prototype, you will need to choose the correct coal bunker and if needed punch out the half etched holes for the rivets.

Class K's did not seem to have been fitted with the early, small plain bunker but this has been provided should you find a loco that did or want to do something different.

All the Class K's have the larger flared bunkers.

#### *Plain bunker.*

For the early plain box type bunker, you will need parts E40 main plain bunker, E48 plain bunker front and E41 plain bunker overlays.

Fold this up and if possible tin the sides and rear beforehand ready for adding the overlays and to help with soldering to the rear bufferbeam.

#### *Flared bunker.*

You will need part E42 main flared bunker.

Punch out the rivets from the half etched circles and form the part with half etched lines on the inside.

Now take E43 flared bunker overlays and punch out the rivets.

Depending on both your prototype and if you wish to do the extra work, some locos like "Morous" may have the flared part of the bunker riveted to the outside of the structure rather than the inside as represented the E43 flared bunker overlays.

To cater for this, parts E44 flared bunker tops are provided for adding to the outside.

The tops of the E43 flared bunker overlays will need to be trimmed off for E44 parts to fit.

Now curve the tops of either E43 flared bunker overlays or E44 flared bunker tops making sure they match each other.

Attach the E43 bunker overlays to the E42 main bunker assembly.

If you are using E44 flared bunker tops, add these on top of the E43 bunker overlays.

Now take E45 flared bunker inside and curve this till it matches well with the edges of E42 main flared bunker assembly and solder this in place.

Now solder E47 bunker internal bracket so it's central between the E45 internal curved bunker inside and the E42 main bunker assembly.

Solder E46 hatches to the E45 curved bunker inside so they are located 1mm from the edges.

Attach either of the coal bunkers to the rear of the footplate and solder in place.

At this stage solder brass wire from the ends of the bunker and cab sides to the footplate to form the cab handrails.



### Saddle tank

Take E56 main saddle tank sides and top and carefully form a curve in the centre section to match the tops of the E57 main saddle tank ends and then the sharp curves.

Once you are happy with shape, fold up the E56 main saddle tank sides to match the E57 main saddle tank ends which the pair should fit flush on the inside. Now tin the outsides of the parts solder all these on the inside to form a solid unit.

Now remove the E58 saddle tank side overlay and straighten them as they may have a slight curve in them. Form to shape to match the main saddle tank assembly and tin pit.

Then solder this to the sides of the saddle tank assembly preferably from inside making sure the holes are at the top and lined up as these will take the handrail knobs later on.

Now take parts E59 saddle tank end overlays and again straighten them as they may have a slight curve in them. Solder these in place making sure they are spaced evenly around the edges, don't worry about them not butting up to the other overlays as this is just like the real locos!

Clean this up of flux and put this aside ready for the next stage.

### Boiler assembly

Remove from the tank fret E53 smoke box front and E54 smoke box wrapper.

Depending on your prototype and even when, you may need to solder onto the front E55 D shaped smoke box door. The bottom of the E55 smoke box door should be level with the bottom of the E53 smoke box front.

Starting from the centre and working outwards, curve the E54 smoke box wrapper to match the E53 smoke box front. Make sure this is formed correctly so it doesn't spring out when doing anymore solder later. Solder the smoke box front and wrapper together.

There is a C5 cast circular smoke box door for later locos supplied and this can be added later during the build of your loco.

Solder 2 small pieces of 0.45mm brass wire into the 2 half etched lines on the tops of the E55 smoke box door.

Now its time to attach the white metal C1 Smokebox, C2 Boiler and C3 Firebox to the C30 footplate, make sure you follow the notes below.

Check that the C30 footplate assembly is straight and not twisted.

The front of the C1 smoke box must be flush with the front opening on the footplate and the rear of the C3 firebox must be flush with the rear opening area.

E78 firebox will need a shallow slot filed to accept the different cabs. An additional slot much deeper will need to be filed to accept the C13 vacuum brake on the right side if your loco is to be fitted with Vacuum brakes but check your prototype.

On the C2 boiler, you will see that there is a cut out section in the middle, this need to be pointing upwards to allows you to glue easily the saddletank and run liquid lead into it.

Place C1 smoke box, C2 boiler and E78 firebox onto the C30 footplate making sure the saddle tank assembly fits easily between the smoke box and firebox.

Once you are happy with this, attach the smoke box, boiler and firebox together with either low melt solder or araldite but not to the footplate as yet.

With LBW4 clacks, it will be very difficult to attach these to the boiler due to being no where near the boiler centre line ruling drilling out as the drill can slip easily and injure yourself or damage the model but me saying that, it can be done. It would be best to solder these to the footplate which needs to be 13mm from the edge of the firebox and the bottom of the actual clack to be 1mm from the footplate .

Now place the completed E53 and E54 smoke box assembly onto the C1 smokebox to check the fit, the edges of the C1 smoke box may have to be rounded off because of the solder. Some of the E53 and E54 may protrude on the around bottom of the smoke box so may need filing to fit flush onto the footplate.

### Cabs

The cabs will vary on your chosen prototype. It may be worth attaching them to the loco body once the boiler assembly is attached to the footplate later on as final detailing can be done with araldite or super glue by attaching the firebox back through the cab and fixed in place but this is down to your personal preference and ease of construction.

All the cabs will need slotting into the top of the firebox.

The first locos will have had fitted E64 weatherboard which will need the large plain brass spectacles fitted to front and back.

Quite a few locos will have had an E65 standard cab design. When removing from the fret, just mark with a pen or pencil the etched lines either side on the fret as these are guides for folding the cab. Also do not cut off the half etched tabs on the back of the cab as these are to attach to the flared coal bunker.

Now fold up slowly using the markings that you have marked checking that it will fit when slotting into the top of the firebox and the back of the flared bunker which it be level with the very top of the bunker. Note that these markings are only a guide and so some adjustments may be needed.

If modelling Ringing Rock later in life, the MW cab will need to be modified by cutting the cab into two separate pieces and joined back together making it shorter in length and overlapping each other, the back should be level with the inside partition of the bunker.

Once you are happy with the fit, remove the E69 MW long cab strips and attach 2 to the inside starting from the rear, these should end up a few millimetres past the centre of the cab. Now take 2 of E70 MW short cab strips and starting from the outside, centre of the cab.

Now form towards the front of the cab and hopefully you will end up with them just protruding from the end of the cab, the 2 different lengths should overlap each other by 1 to 2mm either side of the roof. File these to match the curved aperture on the bottom.

Now solder this to the footplate.

At this stage solder brass wire from the ends of the bunker and cab sides to the footplate.

### Finishing and detailing

The boiler assembly can now be attached to the footplate if you haven't already done so.

The Saddle tank assembly can be attached to the top of the boiler, make sure that this is level before fixing permanently. Hand rail knobs and 0.45mm brass wire can be attached into the holes on the sides of the saddle tank.

At the ends of the saddle tank attach the E75 saddle tank mounting brackets.

If you loco has a round smoke box door, attach C5 round smoke box door to the front of the smokebox. Inserting piece of 0.45mm brass wire into the centre of the smoke box door and then insert onto that E 73 smoke box hand wheel.

Depending on your chosen loco, you may need to fit to the bottom of the smoke box and footplate the E79 smoke box extensions at a 45 degree angle.

Now insert the 6x C12 springs into the slots behind the wheel arches and secure in place.

You will need to file slightly the end of 2 of the springs for the front of the loco to clear the E79 smoke box extensions but then this would be no different from the real locos!

Now working on the C4. Whitemetal firebox backhead drill out the 3 dimples to accept the 2x LBW5. safety valve springs and the LBW8. Regulator handle. If modelling a vacuum braked loco, you will need to fit to the right hand side the C13 vacuum brake which should match the extra slot filed into the rear of the C3. Firebox earlier.

Now attach this to the back of the C3. Firebox making sure the slot in the centre is big enough to accept the cab front of your choice.

Now attach the cab of your choice making sure is level all around.

Now insert into the 2 small slots on the front of the cab the pair of E72 spring balance arms butted up to the LBW5 safety valve springs with the widest part of E72 next to them.

Next fit into the hole on the top of the C3 firebox either LBW1 & 2 E.B.Wilson or LBW3 tapered safety valve covers. If the E72 safety valve spring arms foul the positioning of the dome then these may need filing back.

The LBW9 whistle was usually positioned directly in front of the base of the LBW3 tapered safety valve cover.

Now fit the C14 chimney to the top of the smokebox.

There is provided a pair of LBW6 clack pipe joins, the runs of the pipework and position varied from each loco and also during their career so I'm afraid you will need to refer to photos of your chosen loco for these and when.

Another variation of the Class K's is whether they had sandboxes fitted on the footplate, the size varied and also the general shape.

With the cast C7 small sandboxes and C8 large sandboxes, these are supplied with 90 degree corners, most locos had the corners slight rounded, the edges will need rounding off with a small flat needle file.

### Chassis front profiles

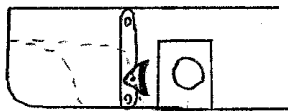

Fig 1, Ringing Rock,  
Small metal brake blocks

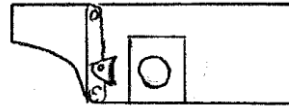
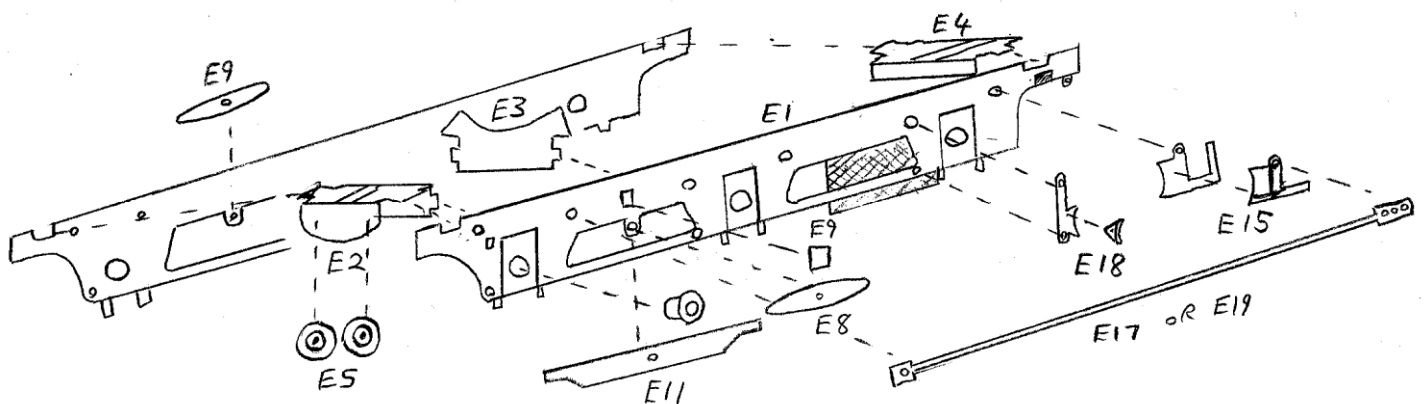

Fig 2, Later locos,  
Small metal brake blocks



Fig 3, Early locos,  
Large Wooden brake blocks



Rear brake linkage arrangement

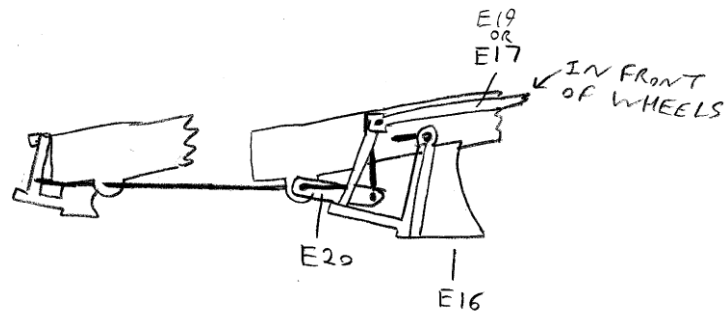

Footplate

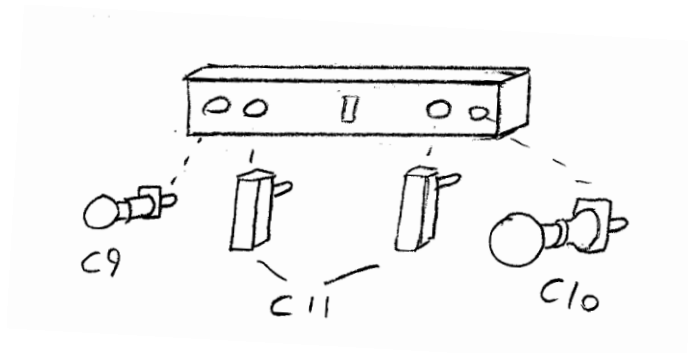
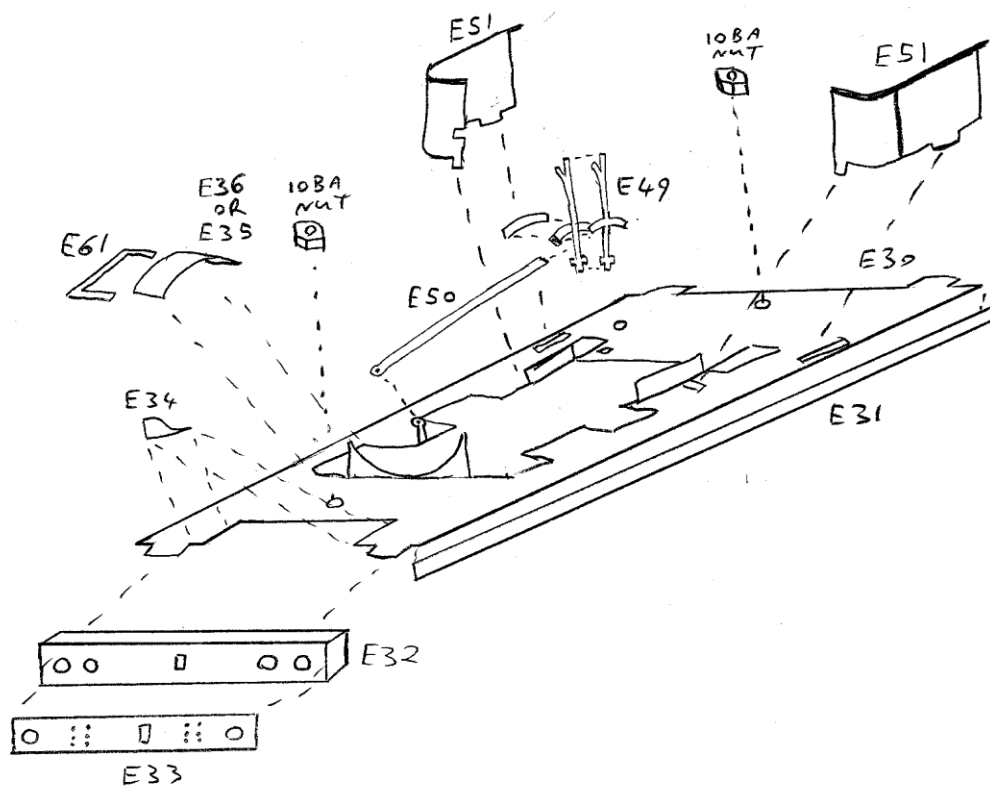

Boiler assembly

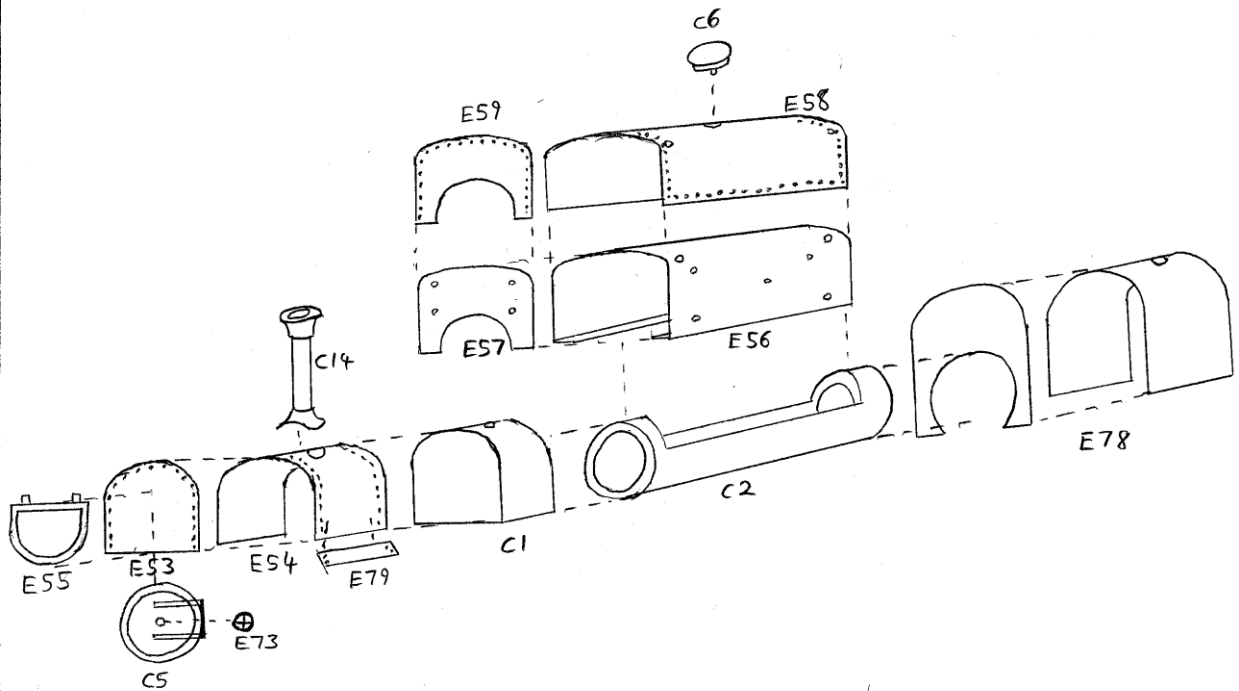

Boiler Fittings

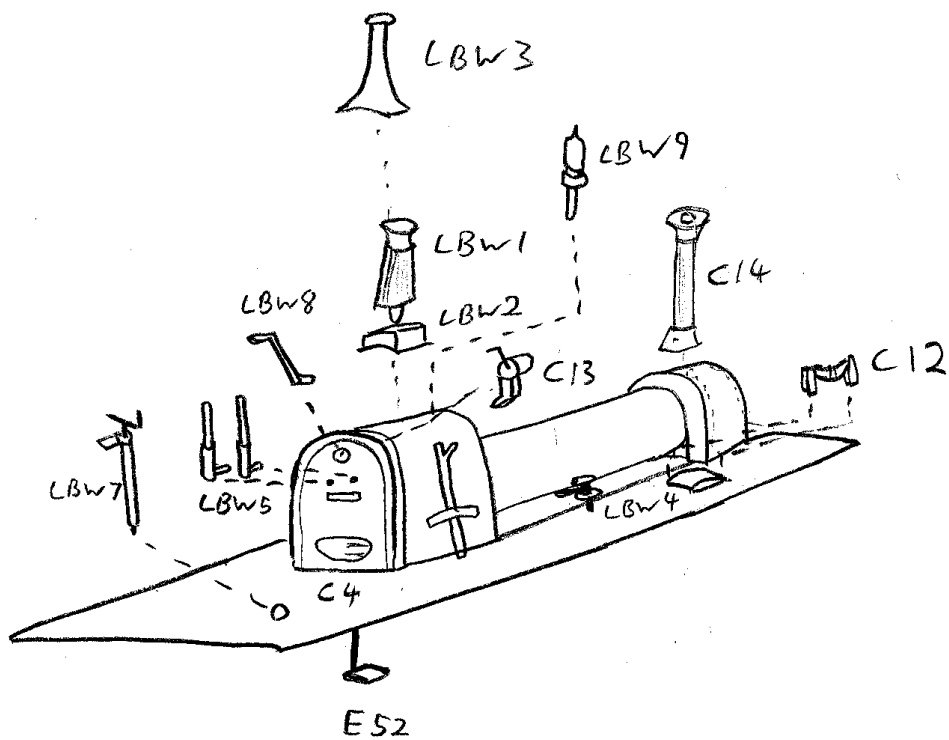

Plain Bunker

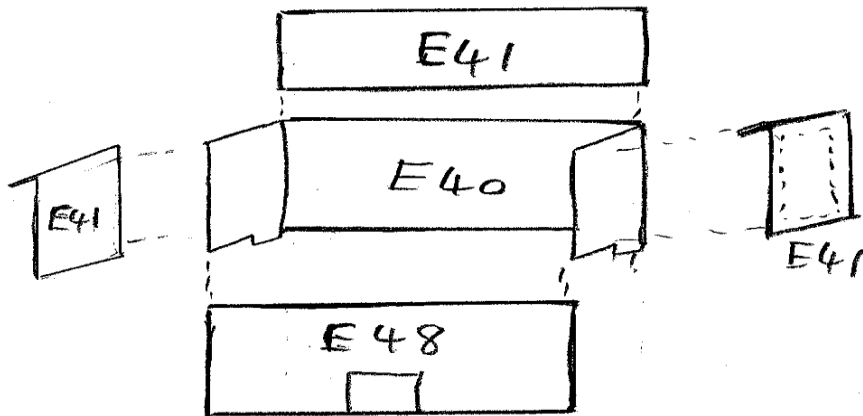

Flared Bunker

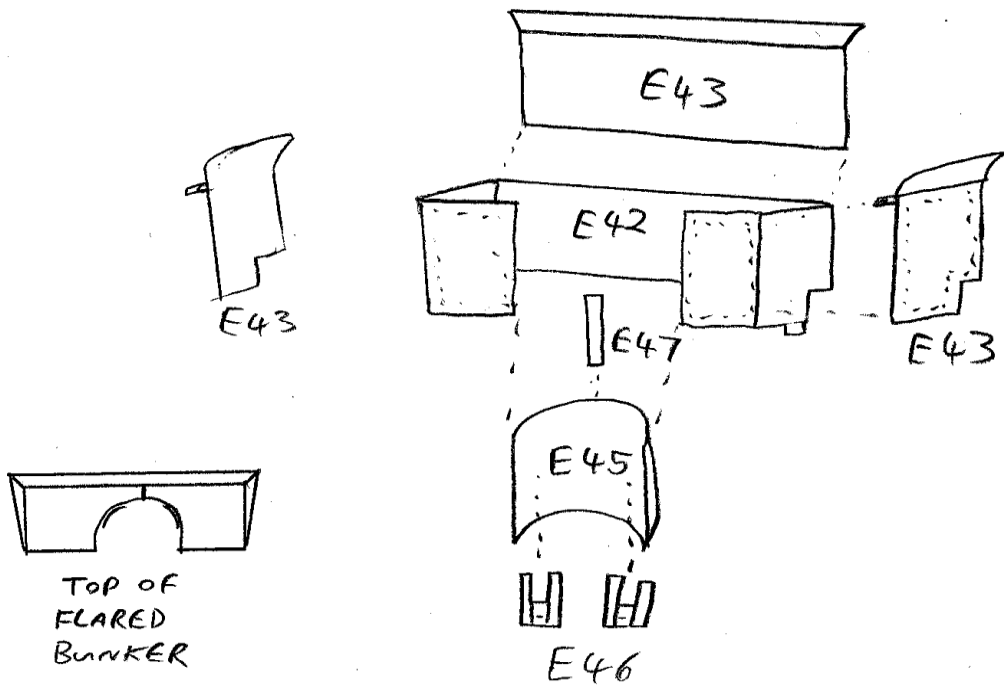

Manning Wardle Cab

